

# MATRIC EXAM REVISIONS

PHYSICAL SCIENCES  
PAPER 2 (2021)

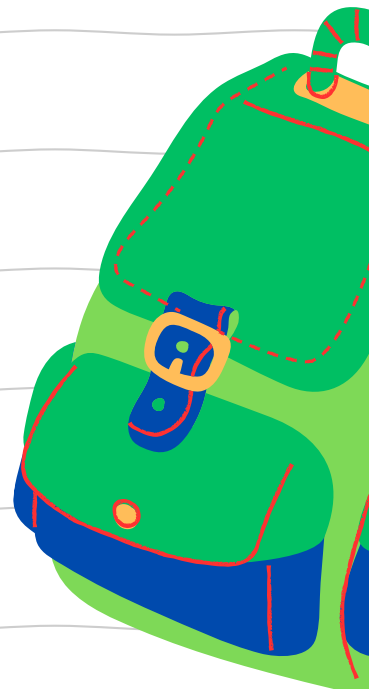

**QUESTION PAPER**





# basic education

Department:  
Basic Education  
**REPUBLIC OF SOUTH AFRICA**

**NATIONAL  
SENIOR CERTIFICATE**

**GRADE 12**

**PHYSICAL SCIENCES: CHEMISTRY (P2)**

**NOVEMBER 2021**

**MARKS: 150**

**TIME: 3 hours**

**This question paper consists of 15 pages and 4 data sheets.**

**INSTRUCTIONS AND INFORMATION**

1. Write your centre number and examination number in the appropriate spaces on the ANSWER BOOK.
2. This question paper consists of NINE questions. Answer ALL the questions in the ANSWER BOOK.
3. Start EACH question on a NEW page in the ANSWER BOOK.
4. Number the answers correctly according to the numbering system used in this question paper.
5. Leave ONE line between two subquestions, e.g. between QUESTION 2.1 and QUESTION 2.2.
6. You may use a non-programmable calculator.
7. You may use appropriate mathematical instruments.
8. Show ALL formulae and substitutions in ALL calculations.
9. Round off your FINAL numerical answers to a minimum of TWO decimal places.
10. Give brief motivations, discussions, etc. where required.
11. You are advised to use the attached DATA SHEETS.
12. Write neatly and legibly.

**QUESTION 1: MULTIPLE-CHOICE QUESTIONS**

Various options are provided as possible answers to the following questions. Choose the answer and write only the letter (A–D) next to the question numbers (1.1 to 1.10) in the ANSWER BOOK, e.g. 1.11 E.

- 1.1 Which formula shows the way in which atoms are bonded in a molecule but does not show all the bond lines? (2)
- A Empirical  
B Molecular  
C Structural  
D Condensed structural
- 1.2 Which ONE of the following compounds has hydrogen bonds between its molecules? (2)
- A  $\text{CH}_3(\text{CH}_2)_2\text{CH}_3$   
B  $\text{CH}_3\text{COCH}_2\text{CH}_3$   
C  $\text{CH}_3\text{COOCH}_2\text{CH}_3$   
D  $\text{CH}_3\text{CH}(\text{OH})\text{CH}_2\text{CH}_3$
- 1.3 Consider the compound below.

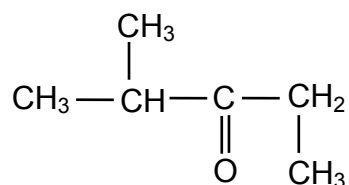

Which ONE of the following is the IUPAC name of this compound?

- A 2-methylpentan-3-one  
B 4-methylpentan-3-one  
C 2,3-dimethylbutan-2-one  
D 2,2,4-trimethylpropan-2-one (2)

- 1.4 A 2 g piece of magnesium reacts with EXCESS hydrochloric acid according to the following balanced equation:

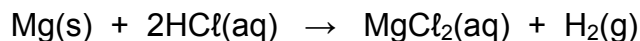

Which ONE of the following changes will INCREASE the YIELD of  $\text{H}_2\text{(g)}$ ?

- A Crush the piece of magnesium.
- B Use a 3 g piece of magnesium.
- C Use a greater volume of the acid.
- D Use a higher concentration of the acid. (2)

- 1.5 The Maxwell-Boltzmann distribution curve **P** represents the number of molecules against kinetic energy for a certain reaction.

Curve **Q** is obtained after a change was made to one reaction condition.

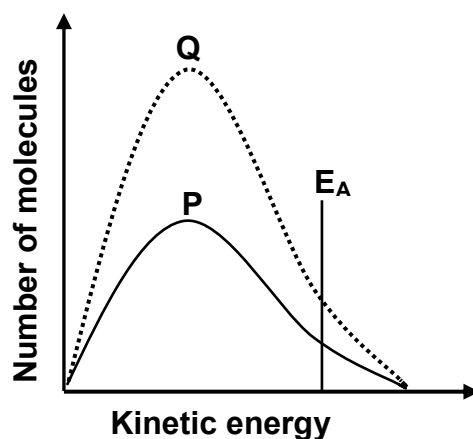

Which ONE of the following changes resulted in curve **Q**?

- A Addition of a catalyst
- B Increase in temperature
- C Increase in activation energy
- D Increase in the concentration of the reactants (2)

- 1.6 The expression for the equilibrium constant ( $K_c$ ) of a hypothetical reaction is given as follows:

$$K_c = \frac{[X]^3}{[Y]^2[Z]}$$

Which ONE of the following equations for a reaction at equilibrium matches the above expression?

- A  $Z(g) + 2Y(g) \rightleftharpoons 3X(s)$
- B  $Z(aq) + 2Y(aq) \rightleftharpoons 3X(l)$
- C  $Z(g) + Y_2(g) \rightleftharpoons 3X(aq) + Q(s)$
- D  $Z(aq) + 2Y(aq) \rightleftharpoons 3X(aq) + Q(s)$  (2)

- 1.7 Two dilute acids of equal concentrations are added to separate test tubes as shown below.

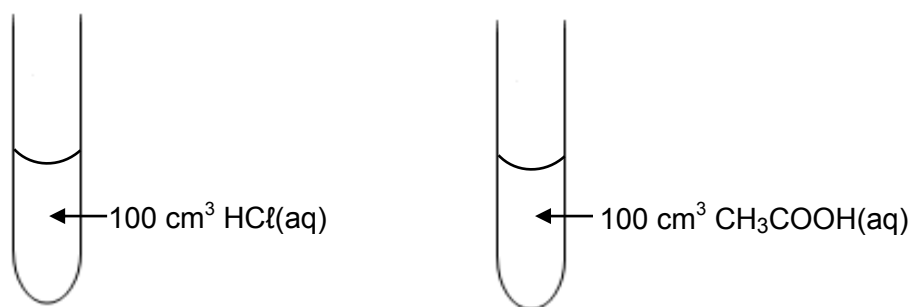

Consider the following statements regarding these acids:

- I:** The pH of each is less than 7.
- II:** Both will react at the same rate with 5 g of magnesium powder.
- III:** Both will neutralise the same number of moles of NaOH(aq).

Which of the statements above is/are TRUE?

- A **I** only
- B **I, II and III**
- C **I and III** only
- D **II and III** only (2)

1.8 Which ONE of the following is the conjugate base of  $\text{H}_2\text{PO}_4^-$ ?

- A  $\text{PO}_4^{3-}$
- B  $\text{HPO}_4^{2-}$
- C  $\text{H}_3\text{PO}_4$
- D  $\text{H}_4\text{PO}_4^+$

(2)

1.9 The diagram below represents a voltaic cell.

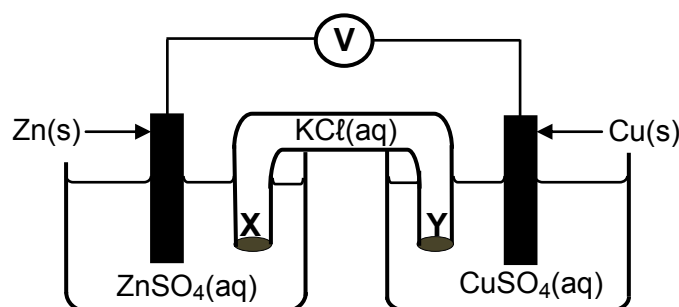

Which ONE of the following correctly describes the movement of ions in the cell?

	TYPE OF IONS	DIRECTION OF MOVEMENT
A	$\text{Cl}^-(\text{aq})$	Y to X
B	$\text{SO}_4^{2-}(\text{aq})$	X to Y
C	$\text{Cu}^{2+}(\text{aq})$	Y to X
D	$\text{K}^+(\text{aq})$	Y to X

(2)

1.10 The diagram below represents a cell that is used for the refining of copper.

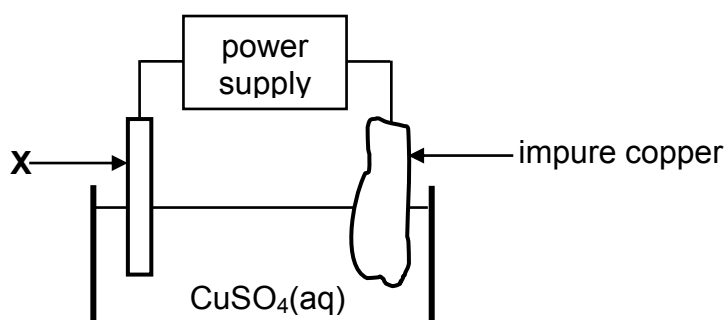

Which ONE of the following statements is TRUE?

- A X is made of platinum.
- B The mass of X increases.
- C X is the electrode where oxidation takes place.
- D X is connected to the positive terminal of the power supply.

(2)  
[20]

**QUESTION 2 (Start on a new page.)**

The letters **A** to **H** in the table below represent eight organic compounds.

<b>A</b>	$\begin{array}{c} \text{H} \quad \quad \text{O} \\   \quad \quad    \\ \text{H}-\text{C}-\text{C}-\text{O}-\text{H} \\   \\ \text{H} \end{array}$	<b>B</b>	$\begin{array}{c} \text{H} \quad \text{H} \\   \quad   \\ \text{H}-\text{C}-\text{C}=\text{C}-\text{CH}_3 \\   \quad   \\ \text{H} \quad \text{CH}_3 \end{array}$
<b>C</b>	$\text{CH}_3\text{CH}_2\text{CH}_2\text{COCH}_3$	<b>D</b>	$\text{C}_2\text{H}_6\text{O}$
<b>E</b>	$\text{C}_2\text{H}_4$	<b>F</b>	3-methylbutan-2-one
<b>G</b>	$\begin{array}{cccccccc} & \text{H} & \text{Cl} & \text{H} & \text{H} & \text{H} & \text{H} & \\ &   &   &   &   &   &   & \\ \text{H} & -\text{C} & -\text{C} & -\text{C} & -\text{C} & -\text{C} & -\text{C} & -\text{H} \\ &   &   &   &   &   &   & \\ & \text{H} & \text{H} & \text{CH}_3 & \text{H} & \text{Cl} & \text{H} & \end{array}$	<b>H</b>	3-methylbutanal

- 2.1 Define the term *unsaturated compound*. (2)
- 2.2 Write down the:
- 2.2.1 Letter that represents an UNSATURATED compound (1)
- 2.2.2 NAME of the functional group of compound **C** (1)
- 2.2.3 Letter that represents a CHAIN ISOMER of compound **C** (2)
- 2.2.4 IUPAC name of compound **G** (3)
- 2.2.5 General formula of the homologous series to which compound **E** belongs (1)
- 2.3 Define the term *functional isomers*. (2)
- 2.4 For compound **A**, write down the:
- 2.4.1 Homologous series to which it belongs (1)
- 2.4.2 STRUCTURAL FORMULA of its FUNCTIONAL isomer (2)
- 2.5 Compound **D** undergoes a dehydration reaction. Write down the:
- 2.5.1 IUPAC name of compound **D** (1)
- 2.5.2 Letter that represents a product of this reaction (1)
- 2.5.3 NAME or FORMULA of the inorganic reactant that is used in this reaction (1)

**[18]**



**QUESTION 3 (Start on a new page.)**

The melting points and boiling points of four straight-chain ALKANES are shown in the table below.

COMPOUND	MELTING POINT (°C)	BOILING POINT (°C)
Pentane	-130	36,1
Hexane	-94	69
Heptane	-90,6	98,4
Octane	-57	125

- 3.1 Define the term *melting point*. (2)
- 3.2 Write down the general conclusion that can be made about the melting points of straight-chain alkanes. (2)
- 3.3 Name the type of Van der Waals forces between molecules of octane. (1)
- 3.4 Write down the predominant phase of the following alkanes at -100 °C.  
Choose from GAS, LIQUID or SOLID.
- 3.4.1 Pentane (1)
- 3.4.2 Octane (1)
- 3.5 Hexane is now compared to 2,2-dimethylbutane.
- 3.5.1 Is the molecular mass of hexane GREATER THAN, LESS THAN or EQUAL to that of 2,2-dimethylbutane?  
Give a reason for the answer. (2)
- 3.5.2 Is the boiling point of 2,2-dimethylbutane HIGHER THAN, LOWER THAN or EQUAL TO that of hexane? (1)
- 3.5.3 Fully explain the answer to QUESTION 3.5.2. (3)
- [13]**

**QUESTION 4 (Start on a new page.)**

- 4.1 Compound **P** is used as a starting reactant in each of two reactions as shown in the flow diagram below.

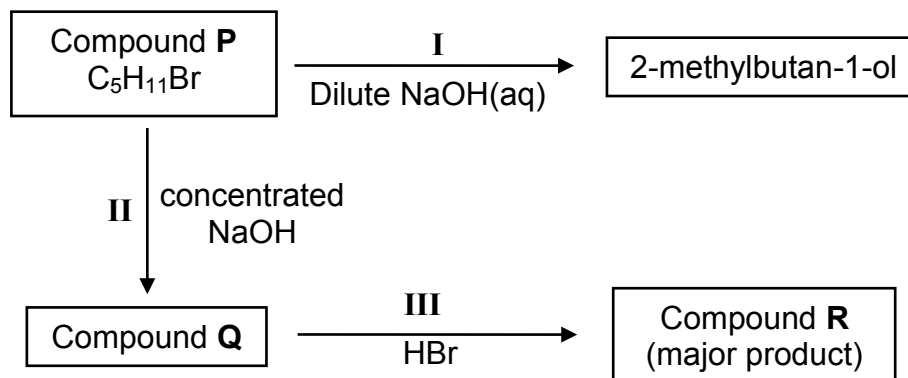

**I**, **II** and **III** represent organic reactions.

- 4.1.1 Name the type of reaction represented by **I**. (1)
- 4.1.2 Is 2-methylbutan-1-ol a PRIMARY, SECONDARY or TERTIARY alcohol? (2)
- Give a reason for the answer. (2)
- 4.1.3 Write down the STRUCTURAL FORMULA of compound **P**. (3)
- 4.1.4 Name the type of reaction represented by **II**. (1)
- 4.1.5 To which homologous series does compound **Q** belong? (1)
- 4.1.6 Name the type of reaction represented by **III**. (1)
- Choose from ADDITION, ELIMINATION or SUBSTITUTION. (1)
- 4.1.7 Write down the IUPAC name of compound **R**. (2)

- 4.2 1,2-dibromopropane can be prepared from but-2-ene by a three-step process as shown in the flow diagram below.

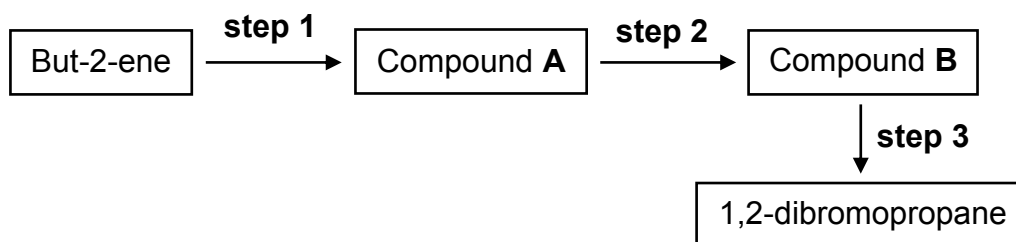

- 4.2.1 Using CONDENSED STRUCTURAL FORMULAE, write down a balanced equation for **step 1**. Indicate the reaction conditions on the arrow. (4)
- 4.2.2 Write down the type of reaction in **step 2**. (1)
- 4.2.3 Write down the IUPAC name of compound **B**. (2)
- 4.2.4 Using CONDENSED STRUCTURAL FORMULAE, write down a balanced equation for **step 3**. (3)
- [21]

**QUESTION 5 (Start on a new page.)**

The reaction of 15 g of an IMPURE sample of calcium carbonate,  $\text{CaCO}_3$ , with EXCESS hydrochloric acid,  $\text{HCl}$ , of concentration  $1,0 \text{ mol}\cdot\text{dm}^{-3}$ , is used to investigate the rate of a reaction. The balanced equation for the reaction is:



The volume of  $\text{CO}_2(\text{g})$  produced is measured at regular intervals. A sketch graph representing the total volume of carbon dioxide gas produced as a function of time is shown below.

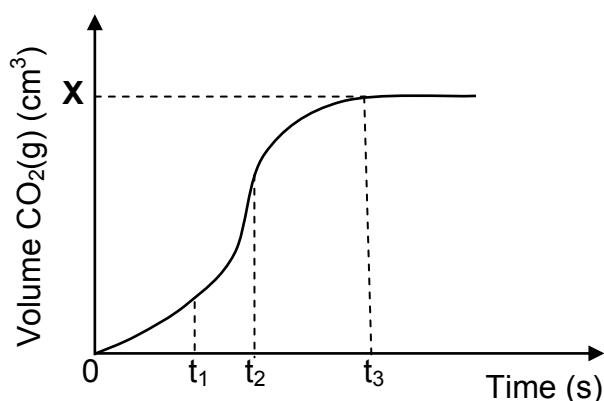

- 5.1 Define the term *reaction rate*. (2)
- 5.2 Give a reason why the gradient of the graph decreases between  $t_2$  and  $t_3$ . (1)
- 5.3 Changes in the graph between  $t_1$  and  $t_2$  are due to temperature changes within the reaction mixture.
- 5.3.1 Is the reaction EXOTHERMIC or ENDOTHERMIC? (1)
- 5.3.2 Explain the answer by referring to the graph. (3)
- 5.4 The percentage purity of the sample is 82,5%.
- Calculate the value of **X** on the graph assuming that the gas is collected at  $25^\circ\text{C}$ . Take the molar gas volume at  $25^\circ\text{C}$  as  $24\,000 \text{ cm}^3$ . (5)
- 5.5 How will the reaction rate change if 15 g of a PURE sample of  $\text{CaCO}_3$  reacts with the same  $\text{HCl}$  solution?
- Choose from INCREASES, DECREASES or REMAINS THE SAME. (1)
- 5.6 Use the collision theory to explain the answer to QUESTION 5.5. (2)

**[15]**

**QUESTION 6 (Start on a new page.)**

Consider the balanced equation below for a hypothetical reaction that takes place in a sealed 2 dm<sup>3</sup> container at 300 K.

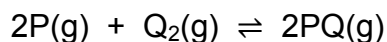

- 6.1 Define the term *chemical equilibrium*. (2)
- 6.2 The amount of each substance present in the equilibrium mixture at 300 K is shown in the table below.

	<b>AMOUNT (mol) AT EQUILIBRIUM</b>
P	0,8
Q <sub>2</sub>	0,8
PQ	3,2

The temperature of the container is now increased to 350 K.

When a NEW equilibrium is established, it is found that 1,2 mol P(g) is present in the container.

- 6.2.1 Is the heat of the reaction ( $\Delta H$ ) POSITIVE or NEGATIVE? (1)
- 6.2.2 Use Le Chatelier's principle to explain the answer to QUESTION 6.2.1. (3)
- 6.2.3 Calculate the equilibrium constant at 350 K. (8)
- 6.2.4 How will the equilibrium constant calculated in QUESTION 6.2.3 be affected when the volume of the container is decreased at constant temperature?
- Choose from INCREASES, DECREASES or REMAINS THE SAME.
- Give a reason for the answer. (2)
- 6.3 More Q<sub>2</sub>(g) is now added to the reaction mixture at constant temperature.
- How will EACH of the following be affected?
- Choose from INCREASES, DECREASES or REMAINS THE SAME.
- 6.3.1 The yield of PQ(g) (1)
- 6.3.2 Number of moles of P(g) (1)

**[18]**

**QUESTION 7 (Start on a new page.)**

7.1 Sulphuric acid,  $\text{H}_2\text{SO}_4$ , ionises into two steps as follows:

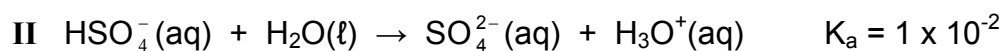
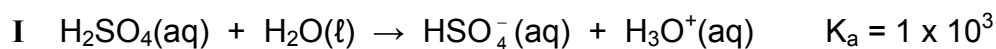

7.1.1 Define an *acid* in terms of the Lowry-Brønsted theory. (2)

7.1.2 Write down the NAME or FORMULA of the substance that acts as an ampholyte in the above equations.

Give a reason for the answer. (2)

7.1.3 The conductivity of solutions of  $\text{HSO}_4^-(\text{aq})$  and  $\text{H}_2\text{SO}_4(\text{aq})$  are compared. Which solution will have a LOWER conductivity?

Explain the answer. (3)

7.2 The pH of a hydrochloric acid solution,  $\text{HCl}(\text{aq})$ , is 1,02 at 25 °C.

7.2.1 Calculate the concentration of the  $\text{HCl}(\text{aq})$ . (3)

This  $\text{HCl}$  solution reacts with sodium carbonate,  $\text{Na}_2\text{CO}_3$ , according to the following balanced equation:

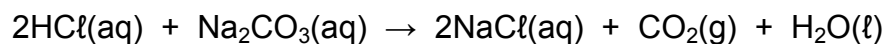

50  $\text{cm}^3$  of the  $\text{HCl}$  solution is added to 25  $\text{cm}^3$  of a 0,075  $\text{mol}\cdot\text{dm}^{-3}$   $\text{Na}_2\text{CO}_3$  solution.

7.2.2 Calculate the concentration of the EXCESS  $\text{HCl}$  in the new solution. (8)

**[18]**

**QUESTION 8 (Start on a new page.)**

The table below shows two half-cells, **A** and **B**, used to assemble an electrochemical cell under STANDARD CONDITIONS.

Half-cell <b>A</b>	$\text{Cu}^{2+}(\text{aq}) \mid \text{Cu}(\text{s})$
Half-cell <b>B</b>	$\text{Ag}^{+}(\text{aq}) \mid \text{Ag}(\text{s})$

- 8.1 State the energy conversion that takes place in this cell. (1)
- 8.2 Calculate the mass of silver nitrate,  $\text{AgNO}_3$ , used to prepare  $150 \text{ cm}^3$  of the electrolyte solution in half-cell **B**. (4)
- 8.3 Define the term *reducing agent*. (2)
- 8.4 Write down the:
- 8.4.1 NAME or FORMULA of the reducing agent (1)
- 8.4.2 Balanced equation for the reaction that takes place (3)
- 8.5 Calculate the initial emf of this cell. (4)
- 8.6 How will the emf of the cell be affected if the concentration of the copper ions in half-cell **A** increases? (1)
- Choose from INCREASES, DECREASES or REMAINS THE SAME. (1)
- [16]**

**QUESTION 9 (Start on a new page.)**

The diagram below shows a simplified electrolytic cell used to electroplate a ring.

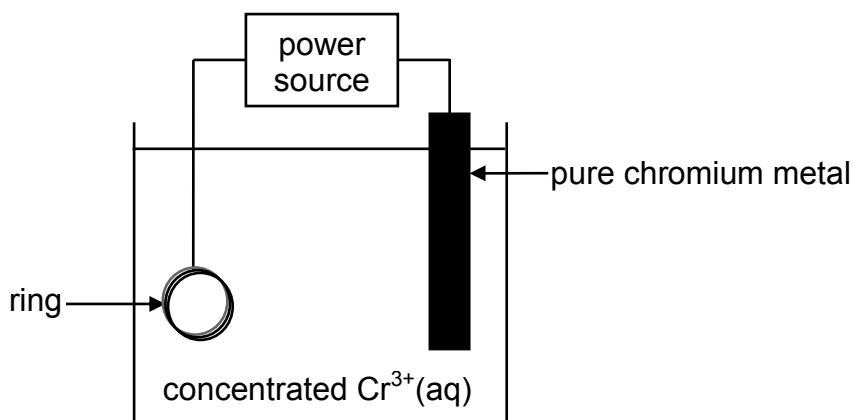

- 9.1 Define the term *electrolyte*. (2)
- 9.2 Is the pure chromium metal the ANODE or the CATHODE of the cell? Give a reason for the answer. (2)
- 9.3 Write down the half-reaction that takes place at the ring. (2)
- 9.4 Calculate the total charge transferred when the mass of the pure chromium changes by 2 g. (5)

**[11]****TOTAL: 150**



**DATA FOR PHYSICAL SCIENCES GRADE 12  
PAPER 2 (CHEMISTRY)**

**GEGEWENS VIR FISIESTE WETENSAPPE GRAAD 12  
VRAESTEL 2 (CHEMIE)**

**TABLE 1: PHYSICAL CONSTANTS/TABEL 1: FISIESTE KONSTANTES**

NAME/NAAM	SYMBOL/SIMBOOL	VALUE/WAARDE
Standard pressure <i>Standaarddruk</i>	$p^\theta$	$1,013 \times 10^5 \text{ Pa}$
Molar gas volume at STP <i>Molêre gasvolume by STD</i>	$V_m$	$22,4 \text{ dm}^3 \cdot \text{mol}^{-1}$
Standard temperature <i>Standaardtemperatuur</i>	$T^\theta$	273 K
Charge on electron <i>Lading op elektron</i>	$e$	$-1,6 \times 10^{-19} \text{ C}$
Avogadro's constant <i>Avogadro-konstante</i>	$N_A$	$6,02 \times 10^{23} \text{ mol}^{-1}$

**TABLE 2: FORMULAE/TABEL 2: FORMULES**

$n = \frac{m}{M}$	$n = \frac{N}{N_A}$
$c = \frac{n}{V}$ or/of $c = \frac{m}{MV}$	$n = \frac{V}{V_m}$
$\frac{c_a V_a}{c_b V_b} = \frac{n_a}{n_b}$	$\text{pH} = -\log[\text{H}_3\text{O}^+]$
$K_w = [\text{H}_3\text{O}^+][\text{OH}^-] = 1 \times 10^{-14}$ at/by 298 K	
$E_{\text{cell}}^\theta = E_{\text{cathode}}^\theta - E_{\text{anode}}^\theta$ / $E_{\text{sel}}^\theta = E_{\text{katode}}^\theta - E_{\text{anode}}^\theta$ or/of $E_{\text{cell}}^\theta = E_{\text{reduction}}^\theta - E_{\text{oxidation}}^\theta$ / $E_{\text{sel}}^\theta = E_{\text{reduksie}}^\theta - E_{\text{oksidasie}}^\theta$ or/of $E_{\text{cell}}^\theta = E_{\text{oxidisingagent}}^\theta - E_{\text{reducingagent}}^\theta$ / $E_{\text{sel}}^\theta = E_{\text{oksideemiddel}}^\theta - E_{\text{reduseemiddel}}^\theta$	

TABLE 3: THE PERIODIC TABLE OF ELEMENTS  
TABEL 3: DIE PERIODIEKE TABEL VAN ELEMENTE

1	2	3	4	5	6	7	8	9	10	11	12	13	14	15	16	17	18																								
(i)	(ii)																	(iii)	(iv)	(v)	(vi)	(vii)	(viii)																		
1 <b>H</b>	2 <b>He</b>																	3 <b>Li</b>	4 <b>Be</b>																	5 <b>B</b>	6 <b>C</b>	7 <b>N</b>	8 <b>O</b>	9 <b>F</b>	10 <b>Ne</b>
11 <b>Na</b>	12 <b>Mg</b>	19 <b>K</b>	20 <b>Ca</b>	21 <b>Sc</b>	22 <b>Ti</b>	23 <b>V</b>	24 <b>Cr</b>	25 <b>Mn</b>	26 <b>Fe</b>	27 <b>Co</b>	28 <b>Ni</b>	29 <b>Cu</b>	30 <b>Zn</b>	31 <b>Ga</b>	32 <b>Ge</b>	33 <b>As</b>	34 <b>Se</b>	35 <b>Br</b>	36 <b>Kr</b>																						
11 <b>Na</b>	12 <b>Mg</b>	19 <b>K</b>	20 <b>Ca</b>	21 <b>Sc</b>	22 <b>Ti</b>	23 <b>V</b>	24 <b>Cr</b>	25 <b>Mn</b>	26 <b>Fe</b>	27 <b>Co</b>	28 <b>Ni</b>	29 <b>Cu</b>	30 <b>Zn</b>	31 <b>Ga</b>	32 <b>Ge</b>	33 <b>As</b>	34 <b>Se</b>	35 <b>Br</b>	36 <b>Kr</b>																						
37 <b>Rb</b>	38 <b>Sr</b>	39 <b>Y</b>	40 <b>Zr</b>	41 <b>Nb</b>	42 <b>Mo</b>	43 <b>Tc</b>	44 <b>Ru</b>	45 <b>Rh</b>	46 <b>Pd</b>	47 <b>Ag</b>	48 <b>Cd</b>	49 <b>In</b>	50 <b>Sn</b>	51 <b>Sb</b>	52 <b>Te</b>	53 <b>I</b>	54 <b>Xe</b>	55 <b>Cs</b>	56 <b>Ba</b>	57 <b>La</b>	58 <b>Ce</b>	59 <b>Pr</b>	60 <b>Nd</b>	61 <b>Pm</b>	62 <b>Sm</b>	63 <b>Eu</b>	64 <b>Gd</b>	65 <b>Tb</b>	66 <b>Dy</b>	67 <b>Ho</b>	68 <b>Er</b>	69 <b>Tm</b>	70 <b>Yb</b>	71 <b>Lu</b>							
87 <b>Fr</b>	88 <b>Ra</b>	89 <b>Ac</b>	91 <b>Zr</b>	92 <b>Nb</b>	96 <b>Mo</b>	101 <b>Ru</b>	103 <b>Rh</b>	106 <b>Pd</b>	108 <b>Ag</b>	112 <b>Cd</b>	115 <b>In</b>	119 <b>Sn</b>	122 <b>Sb</b>	127 <b>Te</b>	128 <b>I</b>	131 <b>Xe</b>	133 <b>Cs</b>	137 <b>Ba</b>	139 <b>La</b>	140 <b>Ce</b>	141 <b>Pr</b>	144 <b>Nd</b>	144 <b>Pm</b>	150 <b>Sm</b>	152 <b>Eu</b>	157 <b>Gd</b>	159 <b>Tb</b>	163 <b>Dy</b>	165 <b>Ho</b>	167 <b>Er</b>	169 <b>Tm</b>	173 <b>Yb</b>	175 <b>Lu</b>								
87 <b>Fr</b>	88 <b>Ra</b>	89 <b>Ac</b>	91 <b>Zr</b>	92 <b>Nb</b>	96 <b>Mo</b>	101 <b>Ru</b>	103 <b>Rh</b>	106 <b>Pd</b>	108 <b>Ag</b>	112 <b>Cd</b>	115 <b>In</b>	119 <b>Sn</b>	122 <b>Sb</b>	127 <b>Te</b>	128 <b>I</b>	131 <b>Xe</b>	133 <b>Cs</b>	137 <b>Ba</b>	139 <b>La</b>	140 <b>Ce</b>	141 <b>Pr</b>	144 <b>Nd</b>	144 <b>Pm</b>	150 <b>Sm</b>	152 <b>Eu</b>	157 <b>Gd</b>	159 <b>Tb</b>	163 <b>Dy</b>	165 <b>Ho</b>	167 <b>Er</b>	169 <b>Tm</b>	173 <b>Yb</b>	175 <b>Lu</b>								
90 <b>Th</b>	91 <b>Pa</b>	92 <b>U</b>	93 <b>Np</b>	94 <b>Pu</b>	95 <b>Am</b>	96 <b>Cm</b>	97 <b>Bk</b>	98 <b>Cf</b>	99 <b>Es</b>	100 <b>Fm</b>	101 <b>Md</b>	102 <b>No</b>	103 <b>Lr</b>						232 <b>Th</b>	238 <b>U</b>	238 <b>Np</b>	238 <b>Pu</b>	238 <b>Am</b>	238 <b>Cm</b>	238 <b>Bk</b>	238 <b>Cf</b>	238 <b>Es</b>	238 <b>Fm</b>	238 <b>Md</b>	238 <b>No</b>	238 <b>Lr</b>										

KEY/SLEUTEL

Atomic number  
AtoomgetalElectronegativity  
Elektronegatiwiteit29  
**Cu**  
63,5Symbol  
SimboolApproximate relative atomic mass  
Benaderde relatiewe atoommassa

**TABLE 4A: STANDARD REDUCTION POTENTIALS**  
**TABEL 4A: STANDAARD-REDUKSIEPOTENSIALE**

Half-reactions/Halfreaksies	$E^\ominus$ (V)
$F_2(g) + 2e^- \rightleftharpoons 2F^-$	+ 2,87
$Co^{3+} + e^- \rightleftharpoons Co^{2+}$	+ 1,81
$H_2O_2 + 2H^+ + 2e^- \rightleftharpoons 2H_2O$	+1,77
$MnO_4^- + 8H^+ + 5e^- \rightleftharpoons Mn^{2+} + 4H_2O$	+ 1,51
$Cl_2(g) + 2e^- \rightleftharpoons 2Cl^-$	+ 1,36
$Cr_2O_7^{2-} + 14H^+ + 6e^- \rightleftharpoons 2Cr^{3+} + 7H_2O$	+ 1,33
$O_2(g) + 4H^+ + 4e^- \rightleftharpoons 2H_2O$	+ 1,23
$MnO_2 + 4H^+ + 2e^- \rightleftharpoons Mn^{2+} + 2H_2O$	+ 1,23
$Pt^{2+} + 2e^- \rightleftharpoons Pt$	+ 1,20
$Br_2(l) + 2e^- \rightleftharpoons 2Br^-$	+ 1,07
$NO_3^- + 4H^+ + 3e^- \rightleftharpoons NO(g) + 2H_2O$	+ 0,96
$Hg^{2+} + 2e^- \rightleftharpoons Hg(l)$	+ 0,85
$Ag^+ + e^- \rightleftharpoons Ag$	+ 0,80
$NO_3^- + 2H^+ + e^- \rightleftharpoons NO_2(g) + H_2O$	+ 0,80
$Fe^{3+} + e^- \rightleftharpoons Fe^{2+}$	+ 0,77
$O_2(g) + 2H^+ + 2e^- \rightleftharpoons H_2O_2$	+ 0,68
$I_2 + 2e^- \rightleftharpoons 2I^-$	+ 0,54
$Cu^+ + e^- \rightleftharpoons Cu$	+ 0,52
$SO_2 + 4H^+ + 4e^- \rightleftharpoons S + 2H_2O$	+ 0,45
$2H_2O + O_2 + 4e^- \rightleftharpoons 4OH^-$	+ 0,40
$Cu^{2+} + 2e^- \rightleftharpoons Cu$	+ 0,34
$SO_4^{2-} + 4H^+ + 2e^- \rightleftharpoons SO_2(g) + 2H_2O$	+ 0,17
$Cu^{2+} + e^- \rightleftharpoons Cu^+$	+ 0,16
$Sn^{4+} + 2e^- \rightleftharpoons Sn^{2+}$	+ 0,15
$S + 2H^+ + 2e^- \rightleftharpoons H_2S(g)$	+ 0,14
<b><math>2H^+ + 2e^- \rightleftharpoons H_2(g)</math></b>	<b>0,00</b>
$Fe^{3+} + 3e^- \rightleftharpoons Fe$	- 0,06
$Pb^{2+} + 2e^- \rightleftharpoons Pb$	- 0,13
$Sn^{2+} + 2e^- \rightleftharpoons Sn$	- 0,14
$Ni^{2+} + 2e^- \rightleftharpoons Ni$	- 0,27
$Co^{2+} + 2e^- \rightleftharpoons Co$	- 0,28
$Cd^{2+} + 2e^- \rightleftharpoons Cd$	- 0,40
$Cr^{3+} + e^- \rightleftharpoons Cr^{2+}$	- 0,41
$Fe^{2+} + 2e^- \rightleftharpoons Fe$	- 0,44
$Cr^{3+} + 3e^- \rightleftharpoons Cr$	- 0,74
$Zn^{2+} + 2e^- \rightleftharpoons Zn$	- 0,76
$2H_2O + 2e^- \rightleftharpoons H_2(g) + 2OH^-$	- 0,83
$Cr^{2+} + 2e^- \rightleftharpoons Cr$	- 0,91
$Mn^{2+} + 2e^- \rightleftharpoons Mn$	- 1,18
$Al^{3+} + 3e^- \rightleftharpoons Al$	- 1,66
$Mg^{2+} + 2e^- \rightleftharpoons Mg$	- 2,36
$Na^+ + e^- \rightleftharpoons Na$	- 2,71
$Ca^{2+} + 2e^- \rightleftharpoons Ca$	- 2,87
$Sr^{2+} + 2e^- \rightleftharpoons Sr$	- 2,89
$Ba^{2+} + 2e^- \rightleftharpoons Ba$	- 2,90
$Cs^+ + e^- \rightleftharpoons Cs$	- 2,92
$K^+ + e^- \rightleftharpoons K$	- 2,93
$Li^+ + e^- \rightleftharpoons Li$	- 3,05

Increasing strength of oxidising agents/Toenemende sterkte van oksideermiddels

Increasing strength of reducing agents/Toenemende sterkte van reduseermiddels

**TABLE 4B: STANDARD REDUCTION POTENTIALS**  
**TABEL 4B: STANDAARD-REDUKSIEPOTENSIALE**

Increasing strength of oxidising agents/Toenemende sterkte van oksideermiddels

Half-reactions/Halfreaksies	$E^\theta$ (V)
$\text{Li}^+ + \text{e}^- \rightleftharpoons \text{Li}$	-3,05
$\text{K}^+ + \text{e}^- \rightleftharpoons \text{K}$	-2,93
$\text{Cs}^+ + \text{e}^- \rightleftharpoons \text{Cs}$	-2,92
$\text{Ba}^{2+} + 2\text{e}^- \rightleftharpoons \text{Ba}$	-2,90
$\text{Sr}^{2+} + 2\text{e}^- \rightleftharpoons \text{Sr}$	-2,89
$\text{Ca}^{2+} + 2\text{e}^- \rightleftharpoons \text{Ca}$	-2,87
$\text{Na}^+ + \text{e}^- \rightleftharpoons \text{Na}$	-2,71
$\text{Mg}^{2+} + 2\text{e}^- \rightleftharpoons \text{Mg}$	-2,36
$\text{Al}^{3+} + 3\text{e}^- \rightleftharpoons \text{Al}$	-1,66
$\text{Mn}^{2+} + 2\text{e}^- \rightleftharpoons \text{Mn}$	-1,18
$\text{Cr}^{2+} + 2\text{e}^- \rightleftharpoons \text{Cr}$	-0,91
$2\text{H}_2\text{O} + 2\text{e}^- \rightleftharpoons \text{H}_2(\text{g}) + 2\text{OH}^-$	-0,83
$\text{Zn}^{2+} + 2\text{e}^- \rightleftharpoons \text{Zn}$	-0,76
$\text{Cr}^{3+} + 3\text{e}^- \rightleftharpoons \text{Cr}$	-0,74
$\text{Fe}^{2+} + 2\text{e}^- \rightleftharpoons \text{Fe}$	-0,44
$\text{Cr}^{3+} + \text{e}^- \rightleftharpoons \text{Cr}^{2+}$	-0,41
$\text{Cd}^{2+} + 2\text{e}^- \rightleftharpoons \text{Cd}$	-0,40
$\text{Co}^{2+} + 2\text{e}^- \rightleftharpoons \text{Co}$	-0,28
$\text{Ni}^{2+} + 2\text{e}^- \rightleftharpoons \text{Ni}$	-0,27
$\text{Sn}^{2+} + 2\text{e}^- \rightleftharpoons \text{Sn}$	-0,14
$\text{Pb}^{2+} + 2\text{e}^- \rightleftharpoons \text{Pb}$	-0,13
$\text{Fe}^{3+} + 3\text{e}^- \rightleftharpoons \text{Fe}$	-0,06
$2\text{H}^+ + 2\text{e}^- \rightleftharpoons \text{H}_2(\text{g})$	<b>0,00</b>
$\text{S} + 2\text{H}^+ + 2\text{e}^- \rightleftharpoons \text{H}_2\text{S}(\text{g})$	+0,14
$\text{Sn}^{4+} + 2\text{e}^- \rightleftharpoons \text{Sn}^{2+}$	+0,15
$\text{Cu}^{2+} + \text{e}^- \rightleftharpoons \text{Cu}^+$	+0,16
$\text{SO}_4^{2-} + 4\text{H}^+ + 2\text{e}^- \rightleftharpoons \text{SO}_2(\text{g}) + 2\text{H}_2\text{O}$	+0,17
$\text{Cu}^{2+} + 2\text{e}^- \rightleftharpoons \text{Cu}$	+0,34
$2\text{H}_2\text{O} + \text{O}_2 + 4\text{e}^- \rightleftharpoons 4\text{OH}^-$	+0,40
$\text{SO}_2 + 4\text{H}^+ + 4\text{e}^- \rightleftharpoons \text{S} + 2\text{H}_2\text{O}$	+0,45
$\text{Cu}^+ + \text{e}^- \rightleftharpoons \text{Cu}$	+0,52
$\text{I}_2 + 2\text{e}^- \rightleftharpoons 2\text{I}^-$	+0,54
$\text{O}_2(\text{g}) + 2\text{H}^+ + 2\text{e}^- \rightleftharpoons \text{H}_2\text{O}_2$	+0,68
$\text{Fe}^{3+} + \text{e}^- \rightleftharpoons \text{Fe}^{2+}$	+0,77
$\text{NO}_3^- + 2\text{H}^+ + \text{e}^- \rightleftharpoons \text{NO}_2(\text{g}) + \text{H}_2\text{O}$	+0,80
$\text{Ag}^+ + \text{e}^- \rightleftharpoons \text{Ag}$	+0,80
$\text{Hg}^{2+} + 2\text{e}^- \rightleftharpoons \text{Hg}(\ell)$	+0,85
$\text{NO}_3^- + 4\text{H}^+ + 3\text{e}^- \rightleftharpoons \text{NO}(\text{g}) + 2\text{H}_2\text{O}$	+0,96
$\text{Br}_2(\ell) + 2\text{e}^- \rightleftharpoons 2\text{Br}^-$	+1,07
$\text{Pt}^{2+} + 2\text{e}^- \rightleftharpoons \text{Pt}$	+1,20
$\text{MnO}_2 + 4\text{H}^+ + 2\text{e}^- \rightleftharpoons \text{Mn}^{2+} + 2\text{H}_2\text{O}$	+1,23
$\text{O}_2(\text{g}) + 4\text{H}^+ + 4\text{e}^- \rightleftharpoons 2\text{H}_2\text{O}$	+1,23
$\text{Cr}_2\text{O}_7^{2-} + 14\text{H}^+ + 6\text{e}^- \rightleftharpoons 2\text{Cr}^{3+} + 7\text{H}_2\text{O}$	+1,33
$\text{Cl}_2(\text{g}) + 2\text{e}^- \rightleftharpoons 2\text{Cl}^-$	+1,36
$\text{MnO}_4^- + 8\text{H}^+ + 5\text{e}^- \rightleftharpoons \text{Mn}^{2+} + 4\text{H}_2\text{O}$	+1,51
$\text{H}_2\text{O}_2 + 2\text{H}^+ + 2\text{e}^- \rightleftharpoons 2\text{H}_2\text{O}$	+1,77
$\text{Co}^{3+} + \text{e}^- \rightleftharpoons \text{Co}^{2+}$	+1,81
$\text{F}_2(\text{g}) + 2\text{e}^- \rightleftharpoons 2\text{F}^-$	+2,87

Increasing strength of reducing agents/Toenemende sterkte van reduseermiddels

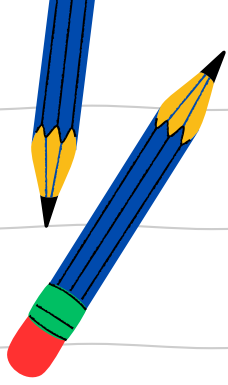

# MATRIC EXAM REVISIONS

PHYSICAL SCIENCES  
PAPER 2 (2021)



**ANSWER PAPER**

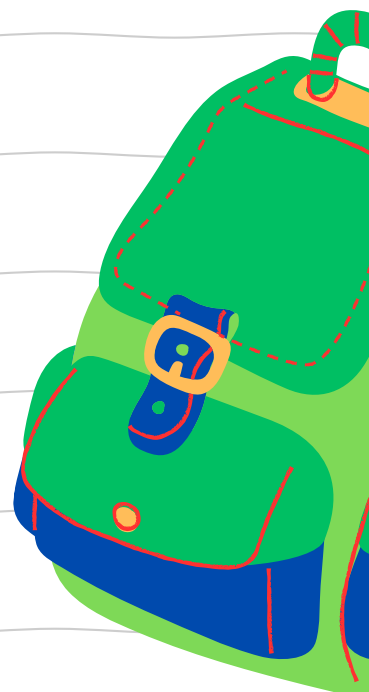



# basic education

Department:  
Basic Education  
**REPUBLIC OF SOUTH AFRICA**

**NATIONAL  
SENIOR CERTIFICATE  
NASIONALE  
SENIOR SERTIFIKAAT**

**GRADE/GRAAD 12**

**PHYSICAL SCIENCES: CHEMISTRY (P2)  
FISIESE WETENSKAPPE: CHEMIE (V2)**

**NOVEMBER 2021**

**MARKING GUIDELINES/NASIENRIGLYNE**

**MARKS/PUNTE: 150**

**These marking guidelines consist of 21 pages.  
*Hierdie nasienriglyne bestaan uit 21 bladsye.***

### QUESTION 1/VRAAG 1

- 1.1 D ✓✓ (2)
- 1.2 D ✓✓ (2)
- 1.3 A ✓✓ (2)
- 1.4 B ✓✓ (2)
- 1.5 D ✓✓ (2)
- 1.6 D ✓✓ (2)
- 1.7 C ✓✓ (2)
- 1.8 B ✓✓ (2)
- 1.9 A ✓✓ (2)
- 1.10 B ✓✓ (2)
- [20]**

### QUESTION 2/VRAAG 2

- 2.1 A compound that contains a double bond/multiple bond/does NOT contain only single bonds (between C atoms). ✓✓ **(2 or 0)**  
*'n Verbinding wat dubbelbindings/meervoudige bindings/NIE net enkelbindings (tussen C-atome) bevat NIE. (2 of 0)* (2)
- 2.2
- 2.2.1 B / E ✓ (1)
- 2.2.2 Carbonyl (group bonded to two C atoms) ✓ **ACCEPT/AANVAAR**  
*Karboniel(groep gebind aan twee C-atome)* Ketone/Ketoon (1)
- 2.2.3 F ✓✓ (2)
- 2.2.4 2,5-dichloro-3-methylhexane/2,5-dichloro-3-metielheksaan

**Marking criteria:**

- Correct stem i.e. hexane. ✓
- All substituents (dichloro and methyl) correctly identified. ✓
- IUPAC name completely correct including numbering, sequence, hyphens and commas. ✓

**Nasienkriteria:**

- *Korrekte stam d.i. heksaan. ✓*
- *Alle substituenten (dichloro en metiel) korrek geïdentifiseer. ✓*
- *IUPAC-naam heeltemal korrek insluitende nommering, volgorde, koppeltekens en kommas. ✓*

(3)

2.2.5  $C_nH_{2n}$  ✓ (1)

2.3 Compounds with the same molecular formula, ✓ but different functional groups/homologous series. ✓  
*Verbindings met dieselfde molekulêre formule, maar verskillende funksionele groepe/homoloë reekse.* (2)

2.4  
 2.4.1 Carboxylic acids/Karboksielsure ✓ (1)

2.4.2

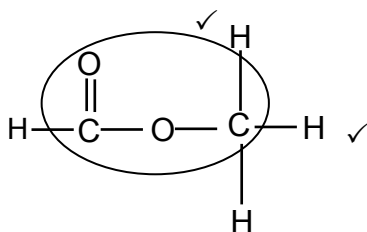

<b>Marking criteria/Nasienkriteria:</b>	
• Whole structure correct/ <i>Hele struktuur korrek:</i>	$\frac{2}{2}$
• Only functional group correct/ <i>Slegs funksionele groep korrek:</i> Max/Maks.:	$\frac{1}{2}$
<b>IF/INDIEN</b>	
More than one functional group: <i>Meer as een funksionele groep:</i>	$\frac{0}{2}$

<b>IF/INDIEN</b>	
• Molecular formula/ <i>Molekulêre formule</i> $\frac{0}{2}$	
• Condensed structural formula / <i>Gekondenseerde struktuurformule</i> $\frac{1}{2}$	

2.5  
 2.5.1 Ethanol/*Etanol* ✓ (1)

2.5.2 E ✓ **ACCEPT/AANVAAR:**  $C_2H_4$  (1)

2.5.3 (Concentrated) sulphuric acid/ $H_2SO_4$ /(concentrated) phosphoric acid/ $H_3PO_4$  ✓  
*(Gekonsentreerde) swawelsuur/  $H_2SO_4$ /(gekonsentreerde) fosforsuur/  $H_3PO_4$*  (1)

**[18]**



### QUESTION 3/VRAAG 3

3.1

**Marking criteria/Nasienkriteria:**

If any one of the underlined key phrases in the **correct context** is omitted, deduct 1 mark.//Indien enige van die onderstreepte frases in die **korrekte konteks** uitgelaat is, trek 1 punt af.

The temperature at which solid and liquid phases are in equilibrium. ✓✓  
Die temperatuur waarby die vastestof- en vloeistoffases van 'n stof in ewewig is.

(2)

3.2

**Marking criteria**

- Identification of independent variable. ✓
- Stating the relationship between dependent and independent variable. ✓

**Nasienkriteria**

- *Identifikasie van onafhanklike veranderlike.* ✓
- *Stel verwantskap tussen afhanklike en onafhanklike veranderlikes.* ✓
- As the chain length/number of C atoms/molecular mass/surface area/strength of the intermolecular forces ✓ increases, the melting points increase. ✓  
**OR**
- As the chain length/ number of C atoms/molecular mass/surface area/strength of the intermolecular forces ✓ decreases, the melting points decrease. ✓
- *Wanneer die kettinglengte/aantal C-atome/molekulêre massa/oppervlak-area/sterkte van intermolekulêre kragte ✓ toeneem, neem die smeltpunte toe.*  
**OF**
- *Wanneer die kettinglengte/aantal C-atome/molekulêre massa/oppervlak-area/sterkte van intermolekulêre kragte afneem, neem die smeltpunte af.*

(2)

3.3

London forces ✓  
Londonkragte

**ACCEPT/AANVAAR**

Dispersion forces/induced dipole forces  
Dispersiekragte/geïnduseerde dipoolkragte

(1)

3.4

3.4.1

Liquid/Vloeistof ✓

(1)

3.4.2

Solid/Vaste stof ✓

(1)

3.5

3.5.1

Equal to/Gelyk aan ✓

Same molecular formula/Isomers/same number and types of atoms/same number of C and H atoms ✓

*Dieselfde molekulêre formule/Isomere/dieselfde aantal en soort atome/dieselfde aantal C- en H-atome*

(2)

3.5.2

Lower than/Laer as ✓

(1)

3.5.3

**Marking criteria:**

- Compare structures. ✓
- Compare the strength of intermolecular forces. ✓
- Compare the energy required to overcome intermolecular forces. ✓

**2,2-dimethylbutane:**

- **Structure:**  
More branched/more compact/more spherical/smaller surface area (over which intermolecular forces act). ✓
- **Intermolecular forces:**  
Weaker/less intermolecular forces/Van der Waals forces/London forces/dispersion forces. ✓
- **Energy:**  
Lesser energy needed to overcome or break intermolecular forces/Van der Waals forces. ✓

OR

**Hexane**

- **Structure:**  
Longer chain length/unbranched/less compact/less spherical/larger surface area (over which intermolecular forces act). ✓
- **Intermolecular forces:**  
Stronger/more intermolecular forces/Van der Waals forces/London forces/dispersion forces. ✓
- **Energy:**  
More energy needed to overcome or break intermolecular forces/Van der Waals forces. ✓

**Nasienkriteria:**

- *Vergelyk strukture* ✓
- *Vergelyk die sterkte van intermolekulêre kragte.* ✓
- *Vergelyk die energie benodig om intermolekulêre kragte te oorkom.* ✓

**2,2-dimetielbutaan:**

- **Struktuur:**  
Meer vertak/meer kompak/meer sferies/kleiner oppervlak (waaroor intermolekulêre kragte werk). ✓
- **Intermolekulêre kragte:**  
Swakker/minder intermolekulêre kragte/Van der Waalskragte/Londonkragte/dispersiekragte. ✓
- **Energie:**  
Minder energie benodig om intermolekulêre kragte/Van der Waalskragte/dispersiekragte/Londonkragte te oorkom/breek. ✓

OF

**Heksaan**

- **Struktuur:**  
Langer kettlinglengte/onvertak/minder kompak/minder sferies/groter oppervlak (waaroor intermolekulêre kragte werk). ✓
- **Intermolekulêre kragte:**  
Sterker/meer intermolekulêre kragte/Van der Waalskragte/Londonkragte/dispersiekragte. ✓
- **Energie:**  
Meer energie benodig om intermolekulêre kragte/Van der Waalskragte/dispersiekragte/Londonkragte te oorkom/breek. ✓

(3)  
[13]

## QUESTION 4/VRAAG 4

4.1

4.1.1 Substitution/Hydrolysis ✓  
Substitusie/Hidrolise

(1)

4.1.2 Primary (alcohol) ✓

**ANY ONE:**

- The C atom of the functional group is the terminal C atom.
- The C-atom bonded to the hydroxyl/-OH is bonded to (only) one other C-atom. ✓
- The hydroxyl/-OH is bonded to a C-atom which is bonded to two hydrogen atoms.
- The hydroxyl/-OH is bonded to a primary C atom/terminal C atom/first C atom.

Primêre (alkohol) ✓

**ENIGE EEN:**

- Die C-*atoom* van die funksionele groep is die terminale C-*atoom*.
- Die C-*atoom* wat aan die hidroksiel/-OH gebind is, is aan (slegs) een ander C-*atoom* gebind. ✓
- Die hidroksiel/-OH is gebind aan 'n C-*atoom* wat aan twee waterstofatome gebind is.
- Die hidroksiel/-OH is aan 'n primêre C-*atoom*/terminale C-*atoom*/eerste C-*atoom* gebind.

(2)

4.1.3

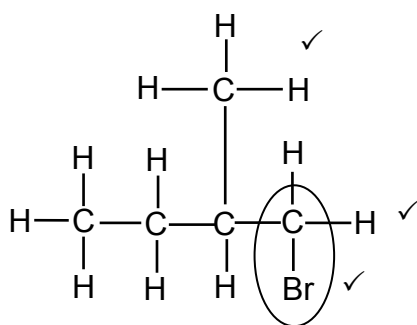

**Marking criteria:**

- Four C atoms in longest chain. ✓
- One methyl substituent on C2. ✓
- Bromo substituent on C1. ✓

**Nasienkriteria:**

- Vier C-*atome* in langste ketting. ✓
- Een metielsubstituent op C2. ✓
- Broomsustituent op C1. ✓

**IF/INDIEN**

Any error e.g. omission of H atoms, condensed or semi structural formula/Enige fout bv. weglating van H-*atome*, gekondenseerde of semi-struktuurformule. Max/Maks.: 2/3

(3)

4.1.4 Elimination/dehydrohalogenation/dehydrobromination ✓  
Eliminasie/dehidrohalogenering/dehidrohalogenasie/dehidrobrominasie/  
dehidrobromonering

(1)

4.1.5 Alkenes/Alkene ✓

(1)

4.1.6 Addition/Addisie ✓

(1)

4.1.7 2-bromo-2-methylbutane ✓  
2-bromo-2-metielbutaan ✓

(2)



## QUESTION 5/VRAAG 5

5.1

### **NOTE/LET WEL**

Give the mark for per unit time only if in context of reaction rate.

Gee die punt vir per eenheidtyd slegs indien in konteks van reaksietempo.

### **ANY ONE**

- Change in concentration ✓ of products/reactants per (unit) time. ✓
- Change in amount/number of moles/volume/mass of products or reactants per (unit) time.
- Amount/number of moles/volume/mass of products formed/reactants used per (unit) time.
- Rate of change in concentration/amount of moles/number of moles/volume/mass. ✓✓ (2 or 0)

### **ENIGE EEN**

- Verandering in konsentrasie ✓ van produkte/reaktans per (eenheid) tyd. ✓
- Verandering in hoeveelheid/getal mol/volume/massa van produkte of reaktans per (eenheid) tyd.
- Hoeveelheid/getal mol/volume/massa van produkte gevorm/reaktans gebruik per (eenheid) tyd.
- Tempo van verandering in konsentrasie/ hoeveelheid mol/getal mol/volume/ massa. ✓✓ (2 of 0)

(2)

5.2

Reaction rate decreases./Concentration of HCl decreases./Concentration of reactant decreases./Reactants are used up/Mass of CaCO<sub>3</sub> decreases or is used up. ✓

Reaksietempo neem af./Konsentrasie van HCl neem af./Konsentrasie van reaktans neem af./Reaktans word opgebruik./Massa van CaCO<sub>3</sub> neem af of word opgebruik. ✓

(1)

5.3

5.3.1

Exothermic/Eksotermies ✓

(1)

5.3.2

- Gradient increases/becomes steeper. / Curve becomes steeper. ✓
- Reaction rate increases/More (or larger volume) of CO<sub>2</sub> is produced per unit time. ✓
- Temperature increases./Energy is released/Average kinetic energy of the molecules increases. ✓

- Gradiënt neem toe/word steiler. / Kurwe word steiler. ✓
- Reaksietempo neem toe./Meer (of groter volume) CO<sub>2</sub> word produseer per eenheidtyd. ✓
- Temperatuur neem toe./Energie word vrygestel./Gemiddelde kinetiese energie van molekule neem toe. ✓

(3)

5.4

<p><b>Marking criteria</b></p> <ul style="list-style-type: none"> <li>• <math>m(\text{pure CaCO}_3) = \frac{82,5}{100} \times 15 \checkmark / V(\text{CO}_2) = \frac{82,5}{100} \times V(\text{CO}_2)</math> from/uit 15 g CaCO<sub>3</sub></li> <li>• Divide by 100 g·mol<sup>-1</sup>. ✓</li> <li>• Use mol ratio: <math>n(\text{CO}_2) = n(\text{CaCO}_3)</math>. ✓</li> <li>• <u>Multiply <math>n(\text{CO}_2)</math> by 24 000 cm<sup>3</sup>/24 dm<sup>3</sup>.</u> ✓</li> <li>• Final answer: 2 976 cm<sup>3</sup> ✓</li> <li>• <b>Range:</b> 2880 to 2970 cm<sup>3</sup> / 2,88 to 2,97 dm<sup>3</sup></li> </ul> <p><b>Nasienkriteria</b></p> <ul style="list-style-type: none"> <li>• <math>m(\text{suiwer CaCO}_3) = \frac{82,5}{100} \times 15 \checkmark / V(\text{CO}_2) = \frac{82,5}{100} \times V(\text{CO}_2)</math> uit 15 g CaCO<sub>3</sub></li> <li>• Deel deur 100 g·mol<sup>-1</sup>. ✓</li> <li>• Gebruik molverhouding: <math>n(\text{CO}_2) = n(\text{CaCO}_3)</math>. ✓</li> <li>• Vermenigvuldig <math>n(\text{CO}_2)</math> met 24 000 cm<sup>3</sup>/24 dm<sup>3</sup>. ✓</li> <li>• Finale antwoord: 2 976 cm<sup>3</sup> ✓</li> <li>• <b>Gebied:</b> 2880 tot 2970 cm<sup>3</sup> / 2,88 tot 2,97 dm<sup>3</sup></li> </ul>	
<p><b>OPTION 1/OPSIE 1</b></p> $m(\text{pure/suiwer CaCO}_3) = \frac{82,5}{100} \times 15 \checkmark$ $= 12,375 \text{ g}$ $n(\text{pure/suiwer CaCO}_3) = \frac{m}{M}$ $= \frac{12,375}{100} \checkmark$ $= 0,124 \text{ mol}$ $n(\text{CO}_2) = n(\text{CaCO}_3)$ $= 0,124 \text{ mol} \checkmark$ $V(\text{CO}_2) = 0,124 \times 24\ 000 \checkmark$ $= 2\ 976 \text{ cm}^3 \checkmark$ <p><b>OR/OF</b></p> $V(\text{CO}_2) = 0,124 \times 24 \checkmark$ $= 2,98 \text{ dm}^3 \checkmark$	<p><b>OPTION 2/OPSIE 2</b></p> <p>IF 15 g PURE CaCO<sub>3</sub> reacts:  <b>INDIEN 15 g SUIWER CaCO<sub>3</sub> reageer:</b></p> $n(\text{CaCO}_3) = \frac{m}{M}$ $= \frac{15}{100} \checkmark$ $= 0,15 \text{ mol}$ $n(\text{CO}_2) = n(\text{CaCO}_3) \checkmark$ $= 0,15 \text{ mol}$ $n(\text{CO}_2) = \frac{V}{V_M}$ $0,15 = \frac{V}{24\ 000} \checkmark / 0,15 = \frac{V}{24}$ $V = 3\ 600 \text{ cm}^3 / V = 3,6 \text{ dm}^3$ <p>Actual CO<sub>2</sub> formed:          Werklike CO<sub>2</sub> gevorm:</p> $V(\text{CO}_2) = \frac{82,5}{100} \times 3\ 600 / 3,6 \checkmark$ $= 2\ 976 \text{ cm}^3 / 2,976 \text{ dm}^3 \checkmark$

(5)

**OPTION 3/OPSIE 3**

**IF 15 g PURE CaCO<sub>3</sub> reacts:/INDIEN 15 g SUIWER CaCO<sub>3</sub> reageer:**

$$n(\text{CaCO}_3) = \frac{m}{M}$$

$$= \frac{15}{100} \checkmark$$

$$= 0,15 \text{ mol}$$

$$n(\text{CO}_2) = n(\text{CaCO}_3) \checkmark$$

$$= 0,15 \text{ mol}$$

$$n(\text{CO}_2) = \frac{m}{M}$$

$$m(\text{CO}_2) = 0,15 \times 44$$

$$= 6,6 \text{ g}$$

$$82,5 = \frac{m_{\text{actual/werklik}}}{6,6} \times 100 \checkmark$$

$$m_{\text{(actual/werklik)}} = 5,445 \text{ g}$$

$$n(\text{CO}_2) = \frac{m}{M}$$

$$= \frac{5,445}{44}$$

$$= 0,12375 \text{ mol}$$

$$n(\text{CO}_2) = \frac{V}{V_M}$$

$$0,12375 = \frac{V}{24\ 000} \checkmark / 0,12375 = \frac{V}{24}$$

$$V = 2\ 976 \text{ cm}^3 / 2,976 \text{ dm}^3 \checkmark$$

(5)

5.5 Increases/*Toeneem* ✓

(1)

- 5.6
- More (CaCO<sub>3</sub>) particles with correct orientation/exposed./ Greater (exposed) surface area. ✓
  - More effective collisions per unit time./Higher frequency of effective collisions. ✓
  - Meer (CaCO<sub>3</sub>)-deeltjies met korrekte oriëntasie/blootgestel./ Groter (blootgestelde) reaksieoppervlakte. ✓
  - Meer effektiewe botsings per eenheid tyd./Hoër frekwensie van effektiewe botsings. ✓

**NOTE/LET WEL**

- If explanation in terms of CONCENTRATION: No mark for bullet 1.  
*Indien verduideliking in terme van KONSENTRASIE: Geen punt vir kolpunt 1.*
- Bullets are marked independently./Kolpunte word onafhanklik nagesien.

(2)

[15]

### QUESTION 6/VRAAG 6

6.1 (The stage in a chemical reaction when the) rate of forward reaction equals the rate of reverse reaction. ✓✓ (2 or 0)

**OR**

(The stage in a chemical reaction when the) concentrations of reactants and products remain constant. (2 or 0)

*(Die stadium in 'n chemiese reaksie wanneer die) tempo van die voorwaartse reaksie gelyk is aan die tempo van die terugwaartse reaksie. (2 of 0)*

**OF**

*(Die stadium in 'n chemiese reaksie wanneer die) konsentrasies van reaktanse en produkte konstant bly. (2 of 0)* (2)

6.2

6.2.1 Negative/Negatief ✓ (1)

6.2.2 • Increase in temperature favours an endothermic reaction.

**Accept:** Decrease in temperature favours an exothermic. ✓

• Reverse reaction is favoured./Concentration of reactants increases./  
Concentration of products decreases. ✓

• (Forward) reaction is exothermic.

**Accept:** Reverse reaction is endothermic. ✓

• *Toename in temperatuur bevoordeel 'n endotermiese reaksie.* ✓

**Aanvaar:** *Afname in temperatuur bevoordeel die eksotermiese reaksie.*

• *Terugwaartse reaksie word bevoordeel./Konsentrasie van reaktanse neem toe./Konsentrasie van produkte neem af.* ✓

• *(Voorwaartse) reaksie is eksotermies.*

**Aanvaar:** *Terugwaartse reaksie is endotermies.* ✓ (3)



6.2.3

**CALCULATIONS USING NUMBER OF MOLES**  
**BEREKENINGE WAT GETAL MOL GEBRUIK**

**Marking criteria:**

- a) Initial n(P) and n(Q<sub>2</sub>) and n(PQ) from table. ✓
- b) Change in n(P) = equilibrium n(P) – initial n(P). ✓
- c) **USING** ratio: P : Q<sub>2</sub> : PQ = 2 : 1 : 2 ✓
- d) Equilibrium n(Q<sub>2</sub>) = initial n(Q<sub>2</sub>) + change in n(Q<sub>2</sub>) } ✓  
 Equilibrium n(PQ) = initial n(PQ) - change in n(PQ) } ✓
- e) Divide **equilibrium** amounts of P and Q<sub>2</sub> and PQ by 2 dm<sup>3</sup>. ✓
- f) Correct K<sub>c</sub> expression (formulae in square brackets). ✓
- g) Substitution of equilibrium concentrations into K<sub>c</sub> expression. ✓
- h) Final answer: 10,889 ✓

**Nasienkriteria:**

- a) *Aanvanklike n(P) en n(Q<sub>2</sub>) en n(PQ) uit tabel.* ✓
- b) *Verandering in n(P) = ewewigs n(P) – aanvanklike n(P).* ✓
- c) **GEBRUIK** verhouding: P : Q<sub>2</sub> : PQ = 2 : 1 : 2 ✓
- d) *Ewewig n(Q<sub>2</sub>) = aanvanklike n(Q<sub>2</sub>) + verandering in n(Q<sub>2</sub>) } ✓*  
*Ewewig n(PQ) = aanvanklike n(PQ) - verandering in n(PQ) } ✓*
- e) *Deel ewewigshoeveelhede van P en Q<sub>2</sub> en PQ deur 2 dm<sup>3</sup>.* ✓
- f) *Korrekte K<sub>c</sub>-uitdrukking (formules in vierkanthakies).* ✓
- g) *Vervanging van ewewigskonsentrasies in K<sub>c</sub>-uitdrukking.* ✓
- h) *Finale antwoord: 10,89 / 10,889* ✓

(3)

**OPTION 1/OPSIE 1**

	P	Q <sub>2</sub>	PQ	
Initial quantity (mol) <i>Aanvangshoeveelheid (mol)</i>	0,8	0,8	3,2	✓(a)
Change (mol) <i>Verandering (mol)</i>	0,4 ✓(b)	0,2	0,4	✓(c)
Quantity at equilibrium (mol)/ <i>Hoeveelheid by ewewig (mol)</i>	1,2	1,0	2,8	✓(d)
Equilibrium concentration (mol·dm <sup>-3</sup> ) <i>Ewewigskonsentrasie (mol·dm<sup>-3</sup>)</i>	0,6	0,5	1,4	✓(e)

$$\begin{aligned}
 K_c &= \frac{[PQ]^2}{[Q_2][P]^2} \quad \checkmark (f) \\
 &= \frac{1,4^2}{(0,5)(0,6)^2} \quad \checkmark (g) \\
 &= 10,89 \quad \checkmark (h)
 \end{aligned}$$

No K<sub>c</sub> expression, correct substitution/Geen K<sub>c</sub>-uitdrukking, korrekte substitusie: Max./Maks.  $\frac{7}{8}$

Wrong K<sub>c</sub> expression/Verkeerde K<sub>c</sub>-uitdrukking: Max./Maks.  $\frac{5}{8}$

**OPTION 2/OPSIE 2**

	PQ	P	Q <sub>2</sub>	
Initial quantity (mol) <i>Aanvangshoeveelheid (mol)</i>	3,2	0,8	0,8	✓(a)
Change (mol) <i>Verandering (mol)</i>	0,4	0,4 ✓(b)	0,2 ✓(c)	
Quantity at equilibrium (mol)/ <i>Hoeveelheid by ewewig (mol)</i>	2,8	1,2 ✓(d)	1,0	
Equilibrium concentration (mol·dm <sup>-3</sup> ) <i>Ewewigskonsentrasie (mol·dm<sup>-3</sup>)</i>	1,4	0,6	0,5	✓(e)

Reverse reaction  
*Terugwaartse reaksie:*

$$K_c = \frac{[P]^2[Q_2]}{[PQ]^2} \quad \checkmark(f)$$

$$= \frac{(0,6)^2(0,5)}{(1,4)^2} \quad \checkmark(g)$$

$$K_c = 0,09$$

Forward reaction/*Voorwaartse reaksie:*

$$K_c = \frac{1}{0,09} \\ = 10,89 \quad \checkmark(h)$$

No K<sub>c</sub> expression, correct substitution/Geen K<sub>c</sub>-uitdrukking, korrekte substitusie: Max./Maks.  $\frac{7}{8}$

Wrong K<sub>c</sub> expression/Verkeerde K<sub>c</sub>-uitdrukking: Max./Maks.  $\frac{5}{8}$

**CALCULATIONS USING NUMBER OF MOLES  
 BEREKENINGE WAT GETAL MOL GEBRUIK**

**Marking criteria:**

- a) Initial  $n(P) = 4$  mol and  $n(Q_2) = 2,4$  mol and  $n(PQ) = 0$  ✓
- b) Change in  $n(P) =$  equilibrium  $n(P) -$  initial  $n(P) = 2,8$  mol. ✓
- c) USING ratio:  $P : Q_2 : PQ = 2 : 1 : 2$  ✓
- d) Equilibrium  $n(Q_2) =$  initial  $n(Q_2) +$  change in  $n(Q_2)$  } ✓  
 Equilibrium  $n(PQ) =$  initial  $n(PQ) -$  change in  $n(PQ)$  }
- e) Divide equilibrium amounts of P and Q<sub>2</sub> and PQ by  $2 \text{ dm}^3$ . ✓
- f) Correct  $K_c$  expression (formulae in square brackets). ✓
- g) Substitution of equilibrium concentrations into  $K_c$  expression. ✓
- h) Final answer:  $10,89 / 10,889$  ✓

**Nasienkriteria:**

- a) Aanvanklike  $n(P) = 4$  mol en  $n(Q_2) = 2,4$  mol en  $n(PQ) = 0$ . ✓
- b) Verandering in  $n(P) =$  ewewigs  $n(P) -$  aanvanklike  $n(P) = 2,8$  mol. ✓
- c) GEBRUIK verhouding:  $P : Q_2 : PQ = 2 : 1 : 2$  ✓
- d) Ewewig  $n(Q_2) =$  aanvanklike  $n(Q_2) +$  verandering in  $n(Q_2)$  } ✓  
 Ewewig  $n(PQ) =$  aanvanklike  $n(PQ) -$  verandering in  $n(PQ)$  }
- e) Deel ewewigshoeveelhede van P en Q<sub>2</sub> en PQ deur  $2 \text{ dm}^3$ . ✓
- f) Korrekte  $K_c$ -uitdrukking (formules in vierkanthakies). ✓
- g) Vervanging van ewewigskonsentrasies in  $K_c$ -uitdrukking. ✓
- h) Finale antwoord:  $10,89 / 10,889$  ✓

**OPTION 3/OPSIE 3**

	P	Q <sub>2</sub>	PQ	
Initial quantity (mol) Aanvangshoeveelheid (mol)	4	2,4	0	✓(a)
Change (mol) Verandering (mol)	2,8 ✓(b)	1,4	2,8	✓(c)
Quantity at equilibrium (mol)/ Hoeveelheid by ewewig (mol)	1,2	1,0	2,8	✓(d)
Equilibrium concentration (mol·dm <sup>-3</sup> ) Ewewigskonsentrasie (mol·dm <sup>-3</sup> )	0,6	0,5	1,4	✓(e)

$$K_c = \frac{[PQ]^2}{[Q_2][P]^2} \checkmark (f)$$

$$= \frac{1,4^2}{(0,5)(0,6)^2} \checkmark (g)$$

$$= 10,89 \checkmark (h)$$

No  $K_c$  expression, correct substitution/Geen  $K_c$ -uitdrukking, korrekte substitusie: Max./Maks.  $\frac{7}{8}$

Wrong  $K_c$  expression/Verkeerde  $K_c$ -uitdrukking: Max./Maks.  $\frac{5}{8}$

**CALCULATIONS USING CONCENTRATION**  
**BEREKENINGE WAT KONSENTRASIE GEBRUIK**

**Marking criteria:**

- a) Initial  $c(P)$  and  $c(Q_2)$  and  $c(PQ)$  from table. ✓
- b) Change in  $c(P)$  = equilibrium  $c(P)$  – initial  $c(P)$ . ✓
- c) **USING** ratio:  $P : Q_2 : PQ = 2 : 1 : 2$  ✓
- d) Equilibrium  $c(Q_2) = \text{initial } c(Q_2) + \text{change in } c(Q_2)$  } ✓  
 Equilibrium  $c(PQ) = \text{initial } c(PQ) - \text{change in } c(PQ)$  }
- e) Divide **initial** amounts of  $P$  and  $Q_2$  and  $PQ$  by  $2 \text{ dm}^3$ . ✓
- f) Correct  $K_c$  expression (**formulae in square brackets**). ✓
- g) Substitution of equilibrium concentrations into  $K_c$  expression. ✓
- h) Final answer:  $10,89 / 10,889$  ✓

**Nasienriglyne:**

- a) Aanvanklike  $c(P)$  en  $c(Q_2)$  en  $c(PQ)$  uit tabel. ✓
- b) Verandering in  $c(P)$  = ewewigs  $c(P)$  – aanvanklike  $c(P)$ . ✓
- c) **GEBRUIK** verhouding:  $P : Q_2 : PQ = 2 : 1 : 2$  ✓
- d) Ewewig  $c(Q_2) = \text{aanvanklike } c(Q_2) + \text{verandering in } c(Q_2)$  } ✓  
 Ewewig  $c(PQ) = \text{aanvanklike } c(PQ) - \text{verandering in } c(PQ)$  }
- e) Deel **aanvangshoeveelhede** van  $P$  en  $Q_2$  en  $PQ$  deur  $2 \text{ dm}^3$ . ✓
- f) Korrekte  $K_c$ -uitdrukking (**formules in vierkanthakies**). ✓
- g) Vervanging van ewewigskonsentrasies in  $K_c$ -uitdrukking. ✓
- h) Finale antwoord:  $10,89 / 10,889$  ✓

**OPTION 4/OPSIE 4**

	P	$Q_2$	PQ	
Initial concentration ( $\text{mol}\cdot\text{dm}^{-3}$ ) Aanvangskonsentrasie ( $\text{mol}\cdot\text{dm}^{-3}$ )	0,4	0,4	1,6	✓ (a)
Change in concentration ( $\text{mol}\cdot\text{dm}^{-3}$ ) Verandering in konsentrasie ( $\text{mol}\cdot\text{dm}^{-3}$ )	0,2 ✓ (b)	0,1	0,2	✓ (c)
Equilibrium concentration ( $\text{mol}\cdot\text{dm}^{-3}$ ) Ewewigskonsentrasie ( $\text{mol}\cdot\text{dm}^{-3}$ )	0,6	0,5	1,4	✓ (d)

$$K_c = \frac{[PQ]^2}{[Q_2][P]^2} \quad \checkmark \text{ (f)}$$

$$= \frac{1,4^2}{(0,5)(0,6)^2} \quad \checkmark \text{ (g)}$$

$$= 10,89 \quad \checkmark \text{ (h)}$$

No  $K_c$  expression, correct substitution/Geen  $K_c$ -uitdrukking, korrekte substitusie: Max./Maks.  $\frac{7}{8}$

Wrong  $K_c$  expression/Verkeerde  $K_c$ -uitdrukking:  
 Max./Maks.  $\frac{5}{8}$

(8)

6.2.4 Remains the same/Bly dieselfde ✓

Only temperature can change  $K_c$ ./Temperature remains constant. ✓  
 Slegs temperatuur kan  $K_c$  verander./Temperatuur bly konstant.

(2)

6.3

6.3.1 Increases/Toeneem ✓

(1)

6.3.2 Decreases/Afneem ✓

(1)

**[18]**

**QUESTION 7/VRAAG 7**

7.1

7.1.1 (It is a) proton/ $H_3O^+$  (ion)/ $H^+$  (ion) donor. ✓✓  
(Dit is 'n) proton/ $H_3O^+$ -(ioon)/ $H^+$ -(ioon)skenker. (2)

7.1.2  $HSO_4^-$ /hydrogen sulphate ion/waterstofsulfaatioon ✓

**ANY ONE:**

- It acts as base in reaction I and as acid in reaction II. ✓
- Acts as acid and base.

**ENIGE EEN:**

- Dit reageer as basis in reaksie I en as suur in reaksie II.
- Reageer as suur en basis. (2)

7.1.3  $HSO_4^-$ /Reaction (solution) II/Reaksie (oplossing) II ✓

Smaller  $K_a$  value/weaker acid ✓

Lower ion concentration/Incompletely ionised. ✓

Kleiner  $K_a$ -waarde/swakker suur ✓

Laer ioonkonsentrasie/Onvolledig geïoniseer. ✓ (3)

7.2

7.2.1

<b><u>OPTION 1/OPSIE 1</u></b>	<b><u>OPTION 2/OPSIE 2</u></b>
pH = $-\log[H_3O^+]$ ✓ 1,02 ✓ = $-\log[H_3O^+]$ $[H_3O^+] = 0,0955 \text{ mol}\cdot\text{dm}^{-3}$ ✓	pH = $-\log[H_3O^+]$ } ✓ Any one/Enige $[H_3O^+] = 10^{-\text{pH}}$ = $10^{-1,02}$ ✓ = $0,0955 \text{ mol}\cdot\text{dm}^{-3}$ ✓
Therefore/Dus $[HCl] = 0,0955 \text{ mol}\cdot\text{dm}^{-3}$ (0,096/0,1 $\text{mol}\cdot\text{dm}^{-3}$ )	Therefore/Dus $[HCl] = 0,0955 \text{ mol}\cdot\text{dm}^{-3}$ (0,096/0,1 $\text{mol}\cdot\text{dm}^{-3}$ )

(3)

7.2.2 **POSITIVE MARKING FROM 7.2.1/POSITIEWE NASIEN VAN VRAAG 7.2.1**

**Marking criteria:**

- Formula:  $c = \frac{n}{V} / \frac{c_a V_a}{c_b V_b} = \frac{n_a}{n_b}$  ✓
- Calculate  $n(\text{Na}_2\text{CO}_3)$ :  $0,075 \times 0,025$  ✓
- Calculate  $n(\text{HCl})$ :  $0,0955 \times 0,05 / 0,096 \times 0,05$  ✓
- Use ratios:  $n(\text{HCl}) = 2n(\text{Na}_2\text{CO}_3)$  ✓
- $n(\text{HCl})_{\text{excess}} = n(\text{HCl})_{\text{initial}} - n(\text{HCl})_{\text{used}} = 0,00475 - 0,0038$  ✓✓
- Substitute  $0,075 \text{ dm}^3$  in  $c = \frac{n}{V}$  ✓
- Final answer:  $0,013 \text{ mol}\cdot\text{dm}^{-3}$  ✓ ( $1,3 \times 10^{-2} \text{ mol}\cdot\text{dm}^{-3}$ )  
**Range:**  $0,01$  to  $0,02 \text{ mol}\cdot\text{dm}^{-3}$

**Nasienkriteria:**

- *Formule:*  $c = \frac{n}{V} / \frac{c_a V_a}{c_b V_b} = \frac{n_a}{n_b}$  ✓
- *Bereken*  $n(\text{Na}_2\text{CO}_3)$ :  $0,075 \times 0,025$  ✓
- *Bereken*  $n(\text{HCl})$ :  $0,0955 \times 0,05 / 0,096 \times 0,05$  ✓
- *Gebruik molverhouding:*  $n(\text{HCl}) = 2n(\text{Na}_2\text{CO}_3)$  ✓
- $n(\text{HCl})_{\text{oormaat}} = n(\text{HCl})_{\text{aanvanklik}} - n(\text{HCl})_{\text{gebruik}} = 0,00475 - 0,0038$  ✓✓
- *Vervang*  $0,075 \text{ dm}^3$  in  $c = \frac{n}{V}$  ✓
- *Finale antwoord:*  $0,013 \text{ mol}\cdot\text{dm}^{-3}$  ✓ ( $1,3 \times 10^{-2} \text{ mol}\cdot\text{dm}^{-3}$ )  
**Gebied:**  $0,01$  tot  $0,02 \text{ mol}\cdot\text{dm}^{-3}$

**OPTION 1/OPSIE 1**

$n(\text{Na}_2\text{CO}_3) = cV$  ✓  
 $= 0,075 \times 0,025$  ✓  
 $= 0,001875 \text{ mol}$  (1,875 x 10<sup>-3</sup>/0,002 mol)

$n(\text{HCl})_{\text{initial/aanvanklik}} = cV$   
 $= 0,096 \times 0,05$  ✓  
 $= 0,00475 \text{ mol}$  (4,75 x 10<sup>-3</sup>/0,005 mol)

$n(\text{HCl})_{\text{used/gebruik}} = 2n(\text{Na}_2\text{CO}_3)$  ✓  
 $= 2(0,001875)$  ✓  
 $= 0,0038 \text{ mol}$  (3,75 x 10<sup>-3</sup>/0,004 mol)

$n(\text{HCl})_{\text{excess/oormaat}} = 0,00475 - 0,0038$  ✓✓  
 $= 0,00095 \text{ mol}$  (9,5 x 10<sup>-4</sup>/1 x 10<sup>-3</sup> mol)

$c(\text{HCl}) = \frac{n}{V}$   
 $= \frac{0,00095}{0,075}$  ✓  
 $= 0,013 \text{ mol}\cdot\text{dm}^{-3}$  ✓ ( $1,3 \times 10^{-2} \text{ mol}\cdot\text{dm}^{-3}$ )

**OPTION 2/OPSIE 2**

$$\frac{c_a V_a}{c_b V_b} = \frac{n_a}{n_b} \checkmark$$

$$\frac{c_a(50)\checkmark}{(0,075)(25)\checkmark} = \frac{2}{1}\checkmark$$

$$c(\text{HCl})_{\text{rea}} = 0,075 \text{ mol}\cdot\text{dm}^{-3}$$

$$c(\text{HCl})_{\text{excess/oormaat}} = 0,0955 - 0,075 \checkmark\checkmark$$

$$= 0,0205 \text{ mol}\cdot\text{dm}^{-3}$$

$$c_1 V_1 = c_2 V_2$$

$$(0,0205)(50) = c_2(75) \checkmark$$

$$c_2 = 0,014 \text{ mol}\cdot\text{dm}^{-3} \checkmark$$

(8)  
[18]

**QUESTION 8/VRAAG 8**

8.1 Chemical (energy) to electrical (energy) ✓  
 Chemiese (energie) na elektriese (energie)

(1)

8.2 **Marking criteria:**

- Any formula:  $c = \frac{m}{MV} / c = \frac{n}{V} / n = \frac{m}{M} \checkmark$
- Substitute  $1 \text{ mol}\cdot\text{dm}^{-3} \checkmark$
- Substitute  $170 \text{ g}\cdot\text{mol}^{-1}$  [or 108 + 14 + 3(16)] and  $0,15 \text{ dm}^3$  in correct formulae. ✓
- Final answer: 25,50 g ✓

**Nasienkriteria:**

- Enige formule:  $c = \frac{m}{MV} / c = \frac{n}{V} / n = \frac{m}{M} \checkmark$
- Vervang  $1 \text{ mol}\cdot\text{dm}^{-3} \checkmark$
- Vervang  $170 \text{ g}\cdot\text{mol}^{-1}$  [of 108 + 14 + 3(16)] en  $0,15 \text{ dm}^3$  in korrekte formules. ✓
- Finale antwoord: 25,50 g ✓

**OPTION 1/OPSIE 1**

$$c = \frac{m}{MV} \checkmark$$

$$1 = \frac{m}{170 \times 0,15} \checkmark$$

$$m = 25,50 \text{ g} \checkmark$$

**OPTION 2/OPSIE 2**

$$n = cV \checkmark$$

$$= 1 \checkmark \times 0,15$$

$$= 0,15 \text{ mol} \checkmark$$

$$m = nM$$

$$= (0,15)(170)$$

$$= 25,50 \text{ g} \checkmark$$

(4)

8.3 **ANY ONE:**

- A substance that loses/donates electrons. ✓✓
- A substance that is oxidised.
- A substance whose oxidation number increases.

**ENIGE EEN:**

- 'n Stof wat elektrone verloor/skenk. ✓✓
- 'n Stof wat geoksideer word.
- 'n Stof wat waarvan die oksidasiegetal toeneem.

(2)

8.4

8.4.1 Copper/Cu/Koper ✓

(1)

8.4.2

**Marking criteria/Nasienkriteria:**

- Reactants ✓ Products ✓ Balancing ✓  
*Reaktanse Produkte Balansering*
- Ignore double arrows./Ignoreer dubbelpyle.
- Ignore phases./Ignoreer fases.
- Marking rule 6.3.10./Nasienreël 6.3.10.

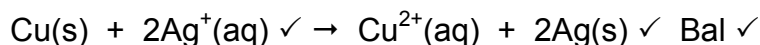

**ACCEPT/AANVAAR:**

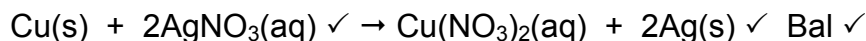

**NOTE/LET WEL**

- **IF** electrons are not cancelled – minus 1 mark
- **INDIEN** elektrone nie gekanselleer is nie – minus 1 punt

(3)

8.5

**OPTION 1/OPSIE 1**

$$E_{\text{cell}}^{\circ} = E_{\text{reduction}}^{\circ} - E_{\text{oxidation}}^{\circ} \checkmark$$

$$= 0,80 \checkmark - (0,34) \checkmark$$

$$= 0,46 \text{ V} \checkmark$$

**Notes/Aantekeninge**

- Accept any other correct formula from the data sheet./Aanvaar enige ander korrekte formule vanaf gegewensblad.
- Any other formula using unconventional abbreviations, e.g.  $E_{\text{cell}}^{\circ} = E_{\text{OA}}^{\circ} - E_{\text{RA}}^{\circ}$  followed by correct substitutions:./Enige ander formule wat onkonvensionele afkortings gebruik bv.  $E_{\text{sel}}^{\circ} = E_{\text{OM}}^{\circ} - E_{\text{RM}}^{\circ}$  gevolg deur korrekte vervangings.  $\frac{3}{4}$

**OPTION 2/OPSIE 2**

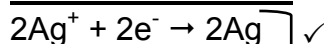

$E^{\circ} = 0,80 \text{ V} \checkmark$

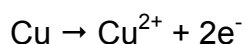

$E^{\circ} = -0,34 \text{ V} \checkmark$

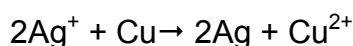

$E^{\circ} = +0,46 \text{ V} \checkmark$

(4)

8.6 Decreases/Afneem ✓

(1)

**[16]**



### QUESTION 9/VRAAG 9

9.1 **ANY ONE: (2 or 0)**

- A substance whose (aqueous) solution contains ions. ✓✓
- Substance that dissolves in water to give a solution that conducts electricity.
- A substance that forms ions in water / when melted.
- A solution that conducts electricity through the movement of ions.

**ENIGE EEN: (2 of 0)**

- 'n Stof waarvan die oplossing ione bevat. ✓✓
- 'n Stof wat in water oplos om 'n oplossing te vorm wat elektrisiteit gelej.
- 'n Stof wat ione in water vorm/ wanneer dit gesmelt word.
- 'n Oplossing wat elektrisiteit gelej deur die beweging van ione. (2)

9.2  Anode ✓

Chromium is oxidised./Oxidation takes place (at the anode)./Chromium (it) loses electrons./Mass decreases./ $\text{Cr} \rightarrow \text{Cr}^{3+} + 3\text{e}^-$  ✓  
Chroom word geoksideer./Oksidasie vind (by die anode) plaas./Chroom (dit) verloor elektrone./Massa neem af./ $\text{Cr} \rightarrow \text{Cr}^{3+} + 3\text{e}^-$

**NOTE/LET WEL:**

If half-reaction is used, it must be correct/Indien halfreaksie gebruik word, moet dit korrek wees:  $\text{Cr} \rightarrow \text{Cr}^{3+} + 3\text{e}^-$  (2)

9.3  $\text{Cr}^{3+}(\text{aq}) + 3\text{e}^- \rightarrow \text{Cr}(\text{s})$  ✓✓

Ignore phases./Ignoreer fases.

**Marking guidelines/Nasienkriteria**

- $\text{Cr}^{3+} + 3\text{e}^- \rightleftharpoons \text{Cr}$   $\frac{1}{2}$        $\text{Cr} \rightleftharpoons \text{Cr}^{3+} + 3\text{e}^-$   $\frac{0}{2}$
  - $\text{Cr} \leftarrow \text{Cr}^{3+} + 3\text{e}^-$   $\frac{2}{2}$        $\text{Cr} \rightarrow \text{Cr}^{3+} + 3\text{e}^-$   $\frac{0}{2}$
  - Ignore if charge omitted on electron./Ignoreer indien lading weggelaat op elektron.
  - If charge (+) omitted on  $\text{Cr}^{3+}$ /Indien lading (+) weggelaat op  $\text{Cr}^{3+}$ : Max./Maks:  $\frac{1}{2}$
- Example/Voorbeeld:  $\text{Cr}^{3+} + 3\text{e}^- \rightarrow \text{Cr}$  ✓ (2)

9.4

<p><b>Marking criteria:</b></p> <ul style="list-style-type: none"> <li>Substitute <math>52 \text{ g}\cdot\text{mol}^{-1}</math> in <math>n = \frac{m}{M}</math> /ratio ✓</li> <li>Use mol ratio: <math>n(\text{electrons}): n(\text{Cr}) = 3 : 1</math>. ✓</li> <li>Number of electrons = <math>n \times 6,02 \times 10^{23}</math> /No of Cr atoms = <math>n \times 6,02 \times 10^{23}</math> /ratio. ✓</li> <li>Total charge = number of electrons <math>\times 1,6 \times 10^{-19}</math> /ratio. ✓</li> <li>Final answer: 11 113,85 C ✓  <b>Range: 11 076,8 to 11 580 C</b></li> </ul> <p><b>Nasienkriteria:</b></p> <ul style="list-style-type: none"> <li>Vervang <math>52 \text{ g}\cdot\text{mol}^{-1}</math> in <math>n = \frac{m}{M}</math> /verhouding ✓</li> <li>Gebruik molverhouding: <math>n(\text{elektrone}) : n(\text{Cr}^{3+}) = 3 : 1</math>. ✓</li> <li>Aantal elektrone = <math>n \times 6,02 \times 10^{23}</math> /Aantal Cr-atome = <math>n \times 6,02 \times 10^{23}</math> /verhouding. ✓</li> <li>Totale lading = aantal elektrone <math>\times 1,6 \times 10^{-19}</math> /verhouding. ✓</li> <li>Finale antwoord: 11 113,85 C ✓  <b>Gebied: 11 076,8 tot 11 580 C</b></li> </ul>					
<p><b>OPTION 1/OPSIE 1</b></p> $n = \frac{m}{M}$ $= \frac{2}{52} \checkmark$ $= 0,038 \text{ mol} \quad (0,04 \text{ mol})$ <p style="margin-left: 40px;">↓</p> $n(e^-) = 3n(\text{Cr}) \checkmark$ $= 3(0,038)$ $= 0,115 \text{ mol} \quad (0,12 \text{ mol})$ <p style="margin-left: 40px;">↓</p> $\text{Number } (e^-) = 0,115 \times 6,02 \times 10^{23} \checkmark$ $= 6,946 \times 10^{22}$ <p style="margin-left: 40px;">↓</p> $Q = 6,95 \times 10^{22} \times 1,6 \times 10^{-19} \checkmark$ $= 11 113,85 \text{ C} \checkmark$	<p><b>OPTION 2/OPSIE 2</b></p> $n = \frac{m}{M}$ $= \frac{2}{52} \checkmark$ $= 0,038 \text{ mol} \quad (0,04 \text{ mol})$ <p>Number Cr atoms  <math>= 0,038 \times 6,02 \times 10^{23} \checkmark</math>  <math>= 2,315 \times 10^{22}</math></p> <p style="margin-left: 40px;">↓</p> $\text{Number } (e^-) = 3N(\text{Cr}) \checkmark$ $= 3(2,315 \times 10^{22})$ $= 6,946 \times 10^{22}$ <p style="margin-left: 40px;">↓</p> $Q = 6,95 \times 10^{22} \times 1,6 \times 10^{-19} \checkmark$ $= 11 113,85 \text{ C} \checkmark$				
<p><b>OPTION 3/OPSIE 3</b></p> $n = \frac{m}{M}$ $= \frac{2}{52} \checkmark$ $= 0,038 \text{ mol}$ <p style="margin-left: 40px;">↓</p> $n(e^-) = 3n(\text{Cr}) \checkmark$ $= 3(0,038)$ $= 0,115 \text{ mol}$ <p style="margin-left: 40px;">↓</p> <table style="width: 100%; border: none;"> <tr> <td style="width: 50%;">1 mol</td> <td style="width: 50%;">96 500 C ✓</td> </tr> <tr> <td>0,115 mol</td> <td>11 134,62 C ✓✓</td> </tr> </table>	1 mol	96 500 C ✓	0,115 mol	11 134,62 C ✓✓	
1 mol	96 500 C ✓				
0,115 mol	11 134,62 C ✓✓				

(5)  
 [11]

**TOTAL/TOTAAL: 150**